

Article number: 2302169308

Description: E+G Stjernegreb VCRT.74 FP-M12

## Measures

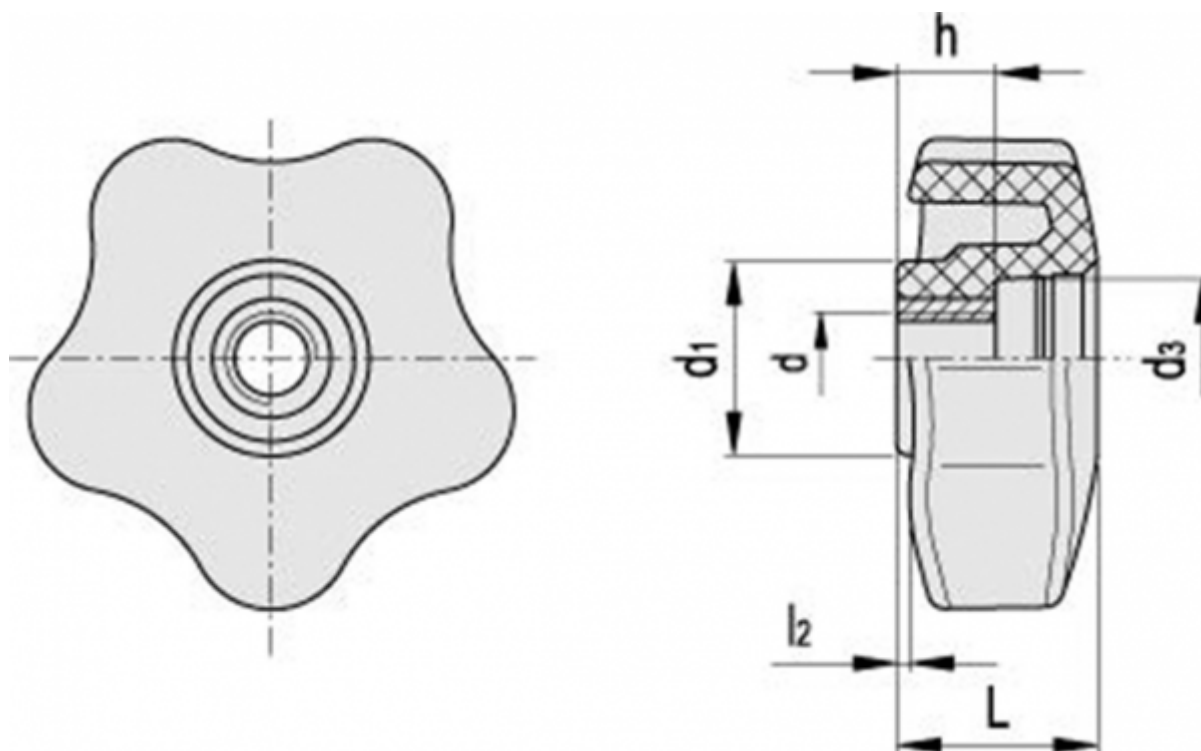

D	= 74
d1	= 26.5
d3	= 19.5
dh	= 12
h	= 15
l2	= 2
L	= 24.5
Weight in (g)	= 47